

PCP - Product Overview



Pump Model		Rate		Pressure		Rotor		Stator (refer to drawing for configuration)			
Netzsch Model	Imperial	B/D (rpm)	m ³ /d (rpm)	Psi	Bar	Length (in.)	Pin Size (in.)	Stator Length (in.)	Stator O.D. (in.)	Stop Pin Length (in.)	Stator Connection (API)
NTZ 166*120ST0.2	1800 -S-1			1800	120	56		35		0	
NTZ 166*150ST0.2	2200 -S-1			2200	150	75		43		0	
NTZ 166*180ST0.2	2600 -S-1	0,01	0,002	2600	180	82	0,7500	50	1,660	0	
NTZ 166*200ST0.2	2900 -S-1			2900	200	88	API	56		0	
NTZ 166*240ST0.2	3500 -S-1			3500	240	98		67		0	1,660-10 NU
NTZ 166*120ST0.8	1800 -S-5			1800	120	78		56		13,7	
NTZ 166*150ST0.8	2200 -S-5			2200	150	101		70		23,6	
NTZ 166*180ST0.8	2600 -S-5	0,05	0,008	2600	180	113	0,7500	82	1,660	23,6	
NTZ 166*200ST0.8	2900 -S-5			2900	200	123	API	92		23,6	
NTZ 166*240ST0.8	3500 -S-5			3500	240	141		109		23,6	1,660-10 EU
NTZ 166*120ST1.1	1800 -S-7			1800	120	99		77		13,7	
NTZ 166*150ST1.1	2200 -S-7			2200	150	128		97		23,6	
NTZ 166*180ST1.1	2600 -S-7	0,07	0,011	2600	180	145	0,7500	113	1,660	23,6	
NTZ 166*200ST1.1	2900 -S-7			2900	200	158	API	127		23,6	
NTZ 166*240ST1.1	3500 -S-7			3500	240	183		152		23,6	1,660-10 NU
NTZ 238*120ST1.6	1800 -S-10			1800	120	89		67		13,7	
NTZ 238*150ST1.6	2200 -S-10			2200	150	115		83		23,6	
NTZ 238*180ST1.6	2600 -S-10	0,10	0,016	2600	180	129	0,9375	97	2,598	23,6	
NTZ 238*200ST1.6	2900 -S-10			2900	200	141	API	109		23,6	
NTZ 238*240ST1.6	3500 -S-10			3500	240	162		131		23,6	2,375-8 EU
NTZ 238*120ST3.2	1800 -S-20			1800	120	104		82		13,7	
NTZ 238*150ST3.2	2200 -S-20			2200	150	134		102		23,6	
NTZ 238*180ST3.2	2600 -S-20	0,20	0,032	2600	180	151	0,9375	119	2,598	23,6	
NTZ 238*200ST3.2	2900 -S-20			2900	200	166	API	134		23,6	
NTZ 238*240ST3.2	3500 -S-20			3500	240	192		160		23,6	2,375-8 EU
NTZ 238*120ST4.0	1800 -S-25			1800	120	131		109		13,7	
NTZ 238*150ST4.0	2200 -S-25			2200	150	169		137		23,6	
NTZ 238*180ST4.0	2600 -S-25	0,25	0,040	2600	180	192	0,9375	160	2,598	23,6	
NTZ 238*200ST4.0	2900 -S-25			2900	200	212	API	180		23,6	
NTZ 238*240ST4.0	3500 -S-25			3500	240	250		219		23,6	2,375-8 EU
NTZ 238*120ST6.2	1800 -S-39			1800	120	159		137		13,7	
NTZ 238*150ST6.2	2200 -S-39			2200	150	204		172		23,6	
NTZ 238*180ST6.2	2600 -S-39	0,39	0,062	2600	180	236	0,9375	204	2,598	23,6	
NTZ 238*200ST6.2	2900 -S-39			2900	200	266	API	234		23,6	
NTZ 238*240ST6.2	3500 -S-39			3500	240	306		274		23,6	2,375-8 EU
NTZ 278*120ST4.0	1800 -S-25			1800	120	122		99		13,7	
NTZ 278*150ST4.0	2200 -S-25			2200	150	157		123		23,6	
NTZ 278*180ST4.0	2600 -S-25	0,25	0,040	2600	180	178	1,0625	145	3,094	23,6	
NTZ 278*200ST4.0	2900 -S-25			2900	200	196	API	162		23,6	
NTZ 278*240ST4.0	3500 -S-25			3500	240	231		197		23,6	2,875-8 EU
NTZ 278*120ST7.0	1800 -S-44			1800	120	122		99		13,7	
NTZ 278*150ST7.0	2200 -S-44			2200	150	157		123		23,6	
NTZ 278*180ST7.0	2600 -S-44	0,44	0,070	2600	180	178	1,0625	145	3,094	23,6	
NTZ 278*200ST7.0	2900 -S-44			2900	200	196	API	162		23,6	
NTZ 278*240ST7.0	3500 -S-44			3500	240	231		198		23,6	2,875-8 EU
NTZ 278*120ST10	1800 -S-63			1800	120	145		122		13,7	
NTZ 278*150ST10	2200 -S-63			2200	150	186		153		23,6	
NTZ 278*180ST10	2600 -S-63	0,63	0,100	2600	180	213	1,1875	179	3,094	23,6	
NTZ 278*200ST10	2900 -S-63			2900	200	242	API	209		23,6	
NTZ 278*240ST10	3500 -S-63			3500	240	277		244		23,6	
NTU 278*150ST10	2200 -S-63	0,63	0,100	2200	150	155		122		23,6	2,875-8 EU
NTZ 278*120ST14	1800 -S-88			1800	120	184		162		13,7	
NTZ278*150ST14	2200 -S-88			2200	150	239		207		23,6	
NTZ278*180ST14	2600 -S-88	0,88	0,140	2600	180	262	1,1875	242	3,094	23,6	
NTZ278*200ST14	2200 -S-88			2900	200	309	API	278		23,6	
NTZ278*240ST14	3500 -S-88			3500	240	357		325		23,6	2,875-8 EU

Pump Model		Rate		Pressure		Rotor		Stator (refer to drawing for configuration)			
Netzsch Model	Imperial	B/D (rpm)	m ³ /d (rpm)	Psi	Bar	Lenght (in.)	Pin Size (in.)	Stator Lenght (in.)	Stator O.D. (in.)	Stop Pin Lenght (in.)	Stator Connection (API)
NTZ 350*120ST16.4	1800 -S-103			1800	120	187		162		13,7	3,500-8 EU
NTZ 350*150ST16.4	2200 -S-103			2200	150	241		207		23,6	
NTZ 350*180ST16.4	2600 -S-103	1,03	0,164	2600	180	277	1,3750	242	3,748	23,6	
NTZ 350*200ST16.4	2900 -S-103			2900	200	312	API	278		23,6	
NTZ 350*240ST16.4	3500 -S-103			3500	240	359		325		23,6	
NTZ 350*120ST20	1800 -S-126			1800	120	198		173		13,7	3,500-8 EU
NTZ 350*150ST20	2200 -S-126			2200	150	252		217		23,6	
NTZ 350*180ST20	2600 -S-126	1,26	0,200	2600	180	292	1,3750	258	3,748	23,6	
NTZ 350*200ST20	2900 -S-126			2900	200	318	API	283		23,6	
NTZ 350*240ST20	3500 -S-126			3500	240	380		346		23,6	
NTZ 350*120ST25	1800 -S-157			1800	120	198		173		13,7	3,500-8 EU
NTZ 350*150ST25	2200 -S-157			2200	150	255		220		23,6	
NTZ 350*180ST25	2600 -S-157	1,57	0,250	2600	180	292	1,3750	258	3,748	23,6	
NTZ 350*200ST25	2900 -S-157			2900	200	330	API	296		23,6	
NTZ 350*240ST25	3500 -S-157			3500	240	381		346		23,6	
NTZ 400*120ST33	1800 -S-208			1800	120	243		219		13,7	4,000-8 NU *
NTZ 400*150ST33	2200 -S-208			2200	150	308		274		23,6	
NTZ 400*180ST33	2600 -S-208	2,08	0,330	2600	180	355	1,3750	321	4,000	23,6	
NTZ 400*200ST33	2900 -S-208			2900	200	402	API	368		23,6	
NTZ 400*240ST33	3500 -S-208			3500	240	471		437		23,6	
NTZ 400*120ST40	1800 -S-252			1800	120	273		257		13,7	4,000-8 NU *
NTZ 400*150ST40	2200 -S-252			2200	150	337		302		23,6	
NTZ 400*180ST40	2600 -S-252	2,52	0,400	2600	180	399	1,3750	365	4,000	23,6	
NTZ 400*200ST40	2900 -S-252			2900	200	435	API	401		23,6	
NTZ 400*240ST40	3500 -S-252			3500	240	548		514		23,6	
NTZ 400*120ST50	1800 -S-315			1800	120	307	1,3750	282		13,7	4,000-8
NTZ 400*150ST50	2200 -S-315	3,15	0,500	2200	150	394	1,5625	360	4,000	23,6	NU
NTZ 400*180ST50	2600 -S-315			2600	180	458	API	423		23,6	*
NTZ 400*090ST62	1310 -S-390			1310	90	288		261		13,7	4,000-8
NTZ 400*100ST62	1450 -S-390			1450	100	316	1,3750	289		13,7	NU
NTZ 400*120ST62	1800 -S-390	3,90	0,620	1800	120	373	1,5625	346	4,000	13,7	*
NTZ 400*150ST62	2200 -S-390			2200	150	470	API	434		23,6	
NTZ 400*090ST78	1310 -S-491			1310	90	284		258		13,7	4,000-8
NTZ 400*120ST78	1800 -S-491	4,91	0,780	1800	120	379	1,5625	352	4,000	13,7	NU
NTZ 400*150ST78	2200 -S-491			2200	150	470	API	434		23,6	*
NTZ 400*090ST120	1310 -S-755	7,55	1,200	1310	90	462	1,5625	437	4,000	13,7	4,000-8*
NTU 500*150ST98	2200 -S-616			2200	150	308	1,5625	270		23,6	5,000-8 LTC
NTU 500*225ST98	3260 -S-616	6,16	0,980	3260	225	443	API	406	5,563	23,6	
NTZ 550*130ST98	1880 -S-912	9,12	1,450	1885	130	308	1,5625	270	5,563	23,6	5,500-8 LTC
NTZ 550*195ST98	2820 -S-912	9,12	1,450	2828	195	443	API	406		23,6	
NTZ 550*100ST145	1450 -S-912	9,12	1,450	1450	100	315	1,5625	289	5,563	13,7	5,500-8 LTC
NTZ 550*150ST145	2200 -S-912			2200	150	469	API	434		23,6	

* Optional for Stator 4,000: Connection 3,500-8 Box EU or 4,000-8 EU

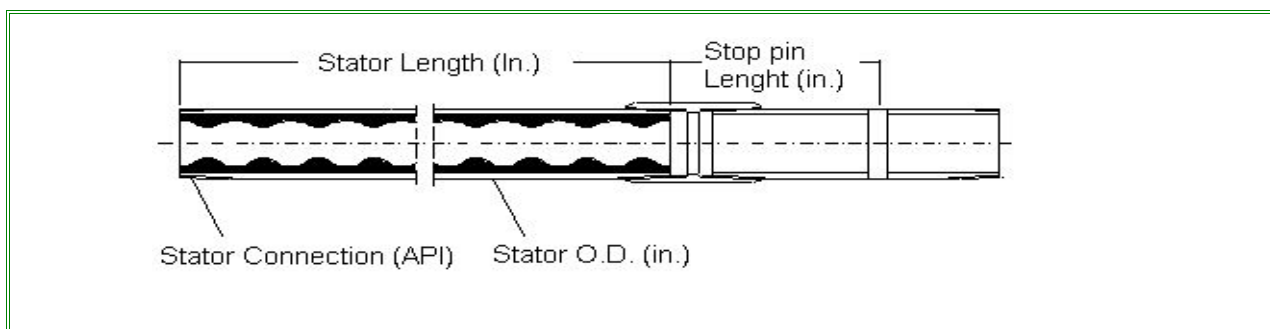

Global Presence

Addresses of all our representatives in 60 countries through the world you can find on:

www.netzsch.com.br



NETZSCH do Brasil
Ind. E Com. Ltda.
Rua Hermann Weege, 2383
BR – 89.107-000 Pomerode / SC
Phone: 55 (47) 3878222
Fax: 55 (47) 3878400
e-mail: info@ndb-netzsch.com.br